

SUITABILITY OF TRANSPORT BY SEA

Ferry companies are occasionally being presented with trailers for shipment, that do not have suitable lashing points for the restraining of trailers at sea using ships lashing equipment.

We would therefore like to remind our customers of the requirements regarding lashing points on their trailers. These requirements are particularly important and will be rigorously enforced on any trailers carrying dangerous goods.

To secure a trailer on the vessel whilst at sea, it is imperative that it is fitted with clearly identifiable and accessible lashing points. These should be available along both sides of the trailer so at the very minimum, 3 lashings per side can be attached in location A and B as outlined below. In particularly bad weather additional lashings may be applied at position C.

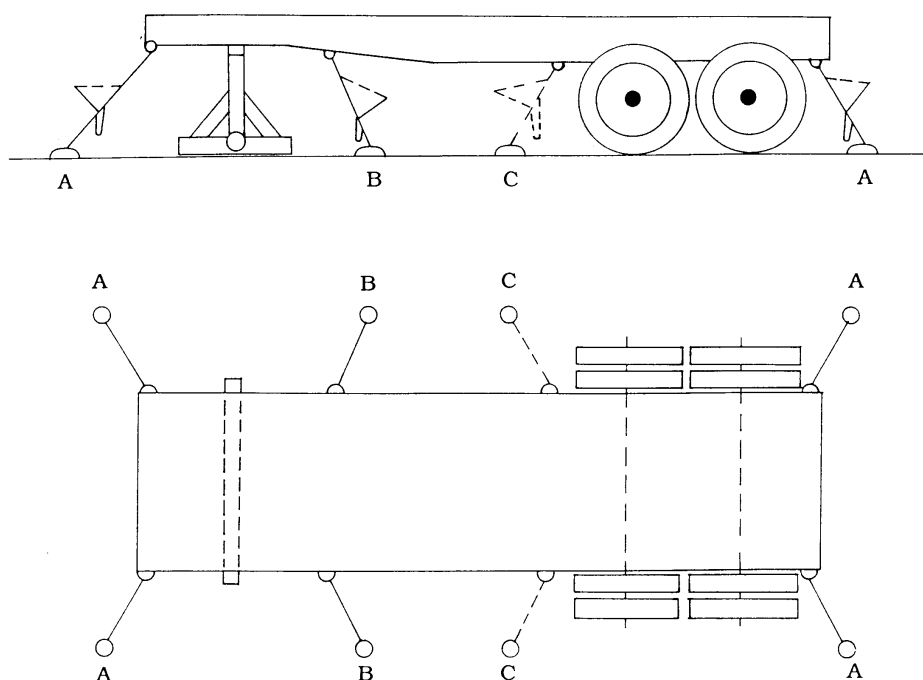

Trailers and similar road vehicles must comply with the specifications in respect of Lashing and Securing arrangements on road vehicles for sea transportation on ro-ro ships. In this respect we are referring to the International Standard ISO 9367-1 and ISO 9367-2 and the specifications as Described in the IMO Resolution A581 (14).

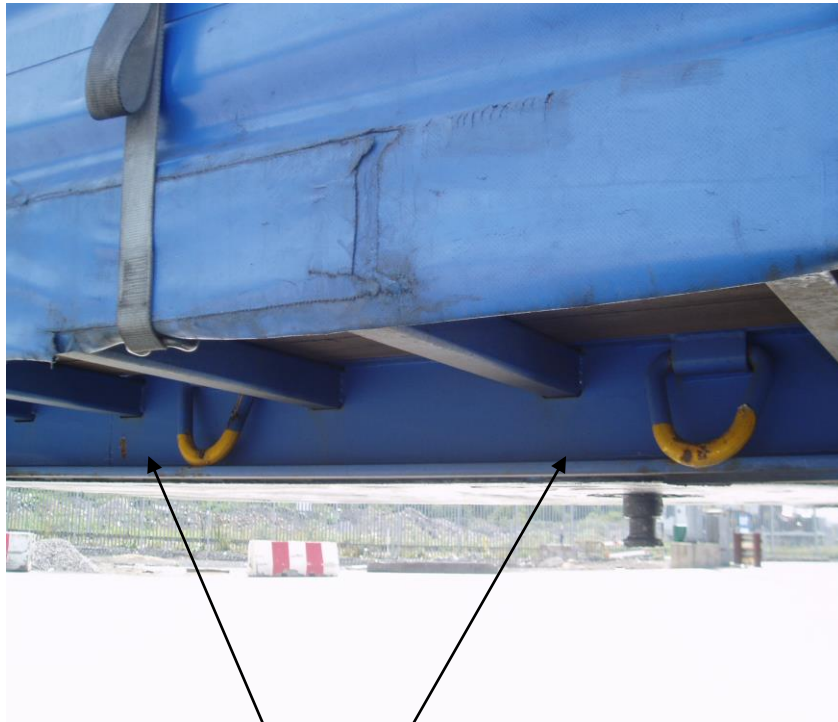

Clearly marked lashing points

We would also like to refer you to the Department of Transport booklet « Roll-on/Roll-off ships – Stowage and Securing of Vehicles, ISBN 0-11-550995-X ». To prevent any short shipment of trailers due to the absence of these lashing points all trailers should be equipped accordingly.